

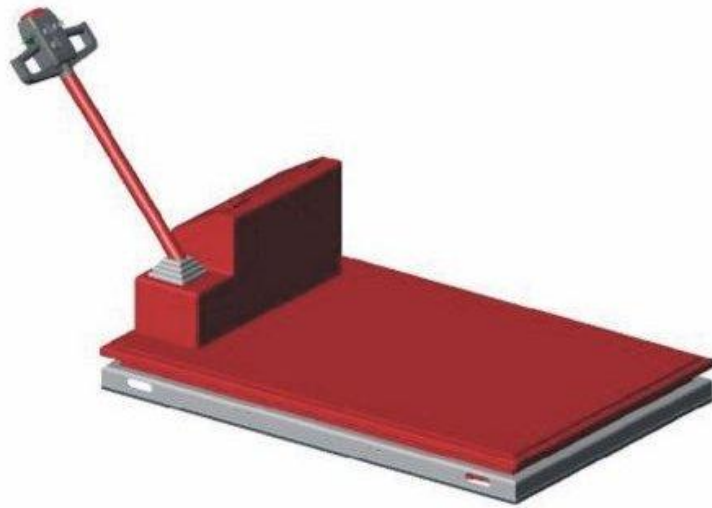

DIRECT-CONTROLLED SOLVING MOVER



Operation

Solving's direct-controlled air film Movers are designed for handling heavy loads placed either on the Mover or on a load pallet, under which the Mover drives.

Integral air bearings lift the Mover and load off the floor and a thin air film is formed between the air bearings and the floor. The Mover then floats virtually friction-free on this air film.

Using built-in drive units the Mover can be driven forwards and backwards at an infinitely adjustable speed, providing good manoeuvrability. When equipped with a steerable drive unit, the Mover can also be driven sideways either to the right or left.

Solving's air film Mover provides a very high degree of safety and protection for both personnel and goods. The air film Mover requires a minimum of maintenance and is a cost-effective solution to material handling needs.



Safety guard

A safety guard around the Mover minimises injuries and prevents debris from entering the air bearing area.



Slide-mounted air bearings

The air bearings are slide-mounted for easy inspection or replacement without unloading or lifting the Mover.



Drive unit

The air or electric drive unit maintains contact with the floor at all times using an air suspension system.

Creating Movement

Construction

The air film Mover consists of a load carrying steel frame covered with floor plate. The air bearings are mounted in the corners under the Mover and the drive units are centrally placed under the load. Steerable drive units are rotated using an air cylinder. When handling pallets, the Mover is equipped with 'no load' wheels to enable the unit to be driven under the pallet.

The Mover's control system is mounted in the control console from where the operator can control and supervise all functions.

The pressure in the air bearings is automatically regulated according to the weight of the load and the position of the centre of gravity.

Technical information

DIRECT-CONTROLLED SOLVING MOVER

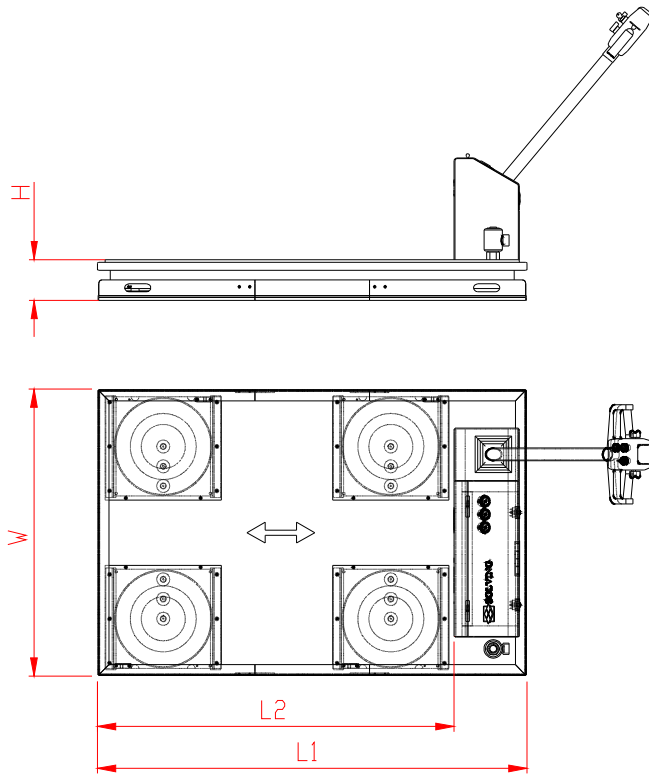

Type	Capacity Tonnes	Length L1 mm	Length L2 mm	Width W mm	Height H mm	Air consumption NI / min
SAPT5C-1X	5	1650	1370	1100	155	2650
SAPT5C-1XY	5	2100	1820	1100	175	2650



Creating Movement



Ab Solving Oy
PO Box 98
FI-68601 Jakobstad
FINLAND
Tel +358 6 781 7500
Fax +358 6 781 7510
info@solving.fi
www.solving.fi