

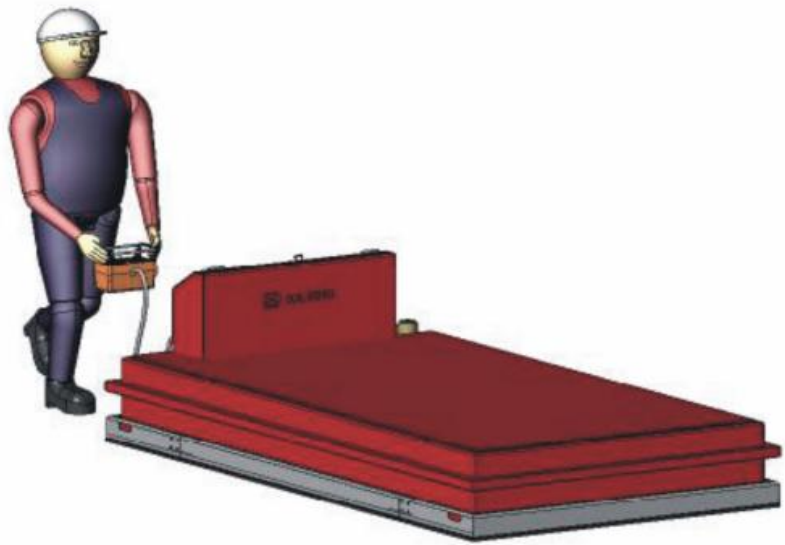

# REMOTE-CONTROLLED SOLVING MOVER



## Operation

Solving's remote controlled air film Movers are designed for handling heavy loads placed either directly on the Mover or on a load pallet. The remote control unit enables the operator to move freely around the load and choose the best position for maximum safety during the move.

Integral air bearings lift the Mover and load off the floor and a thin air film is formed between the air bearings and the floor. The Mover then floats virtually friction-free on this air film.

Using two built-in drive units the Mover can be driven forwards/backwards, around corners and rotate around its own centre at infinitely variable speeds.

Solving's air film Mover provides a very high degree of safety and protection for both personnel and goods. The air film Mover requires a minimum of maintenance and is a cost-effective solution to material handling needs.



### Safety guard

A safety guard around the Mover minimises injuries and prevents debris from entering the air bearing area.



### Slide-mounted air bearings

The air bearings are slide-mounted for easy inspection or replacement without unloading or lifting the Mover.



### Drive unit

The air or electric drive unit maintains contact with the floor at all times using an air suspension system.

# Creating Movement

## Construction

The air film Mover consists of a load carrying steel frame covered with floor plate. The air bearings are mounted in the corners under the Mover and the drive units are centrally placed under the load. When handling pallets, the Mover is equipped with 'no load' wheels to enable the unit to be driven under the pallet.

The air film Mover's control system is mounted under a cover in the steel frame providing easy access for inspection.

The pressure in the air bearings is automatically regulated in relation to the weight of the load and the position of the centre of gravity.

## Technical information

### REMOTE-CONTROLLED SOLVING MOVER

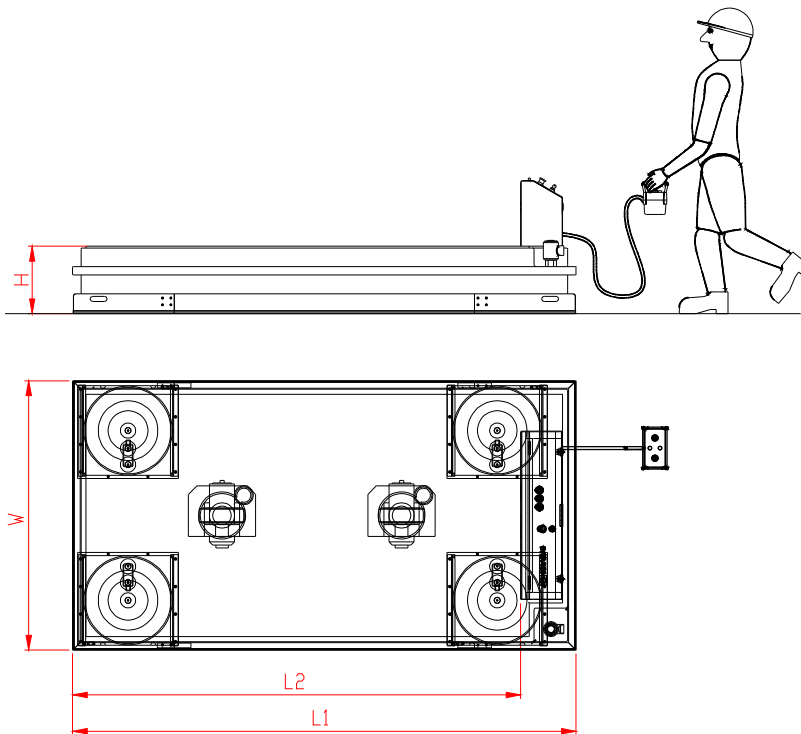

| Type        | Capacity<br>Tonnes | Length<br>L1 mm | Length<br>L2 mm | Width<br>W mm | Height<br>H mm | Air consumption<br>NI / min |
|-------------|--------------------|-----------------|-----------------|---------------|----------------|-----------------------------|
| SAPT10R-2X  | 10                 | 2250            | 1950            | 1400          | 155            | 3500                        |
| SAPT10R-2XY | 10                 | 3400            | 3100            | 1400          | 195            | 3500                        |
| SAPT24R-2R* | 24                 | 3000            | 2670            | 1600          | 400            | 3400                        |
| SAPT24R-2XY | 24                 | 3400            | 3070            | 1600          | 240            | 4700                        |

\* Electric drive units



Ab Solving Oy  
PO Box 98  
FI-68601 Jakobstad  
FINLAND  
Tel +358 6 781 7500  
Fax +358 6 781 7510

info@solving.fi  
www.solving.fi

Creating Movement

